

Broadband DSX

User Manual

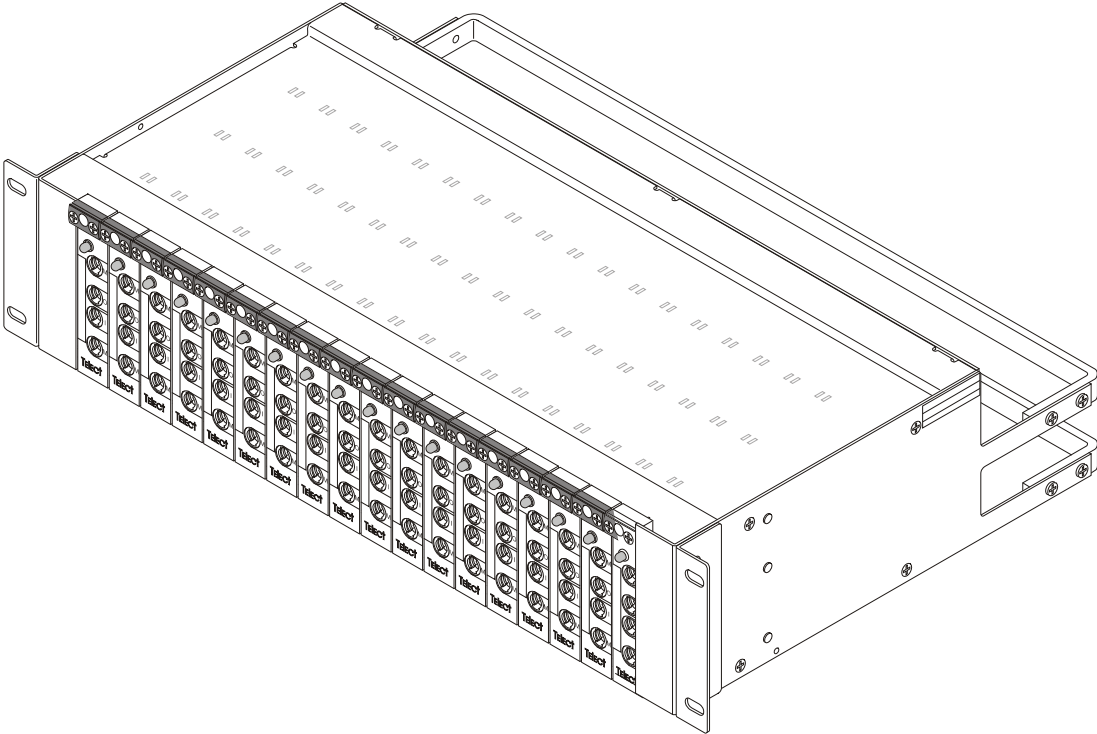

Broadband DSX

User Manual, Part Number 109374-3

Copyright 2010, Telect, Inc., All Rights Reserved

Telect and Connecting the Future are registered trademarks of Telect, Inc.

1730 N Madson St., Liberty Lake, Washington

Telect assumes no liability from the application or use of these products. Neither does Telect convey any license under its patent rights nor the patent rights of others. This document and the products described herein are subject to change without notice.

About Telect

Telect offers complete solutions for physical layer connectivity, power, equipment housing and other network infrastructure equipment. From outside plant and central office to inside the home, Telect draws on more than 25 years of experience to deliver leading edge product and service solutions. Telect is committed to providing superior customer service and is capable of meeting the dynamic demands of customer and industry requirements. This commitment to customer and industry excellence has positioned Telect as a leading connectivity and power solution provider for the global communications industry.

Technical Support

E-mail: getinfo@telect.com

Phone: 888-821-4856 or 509-921-6161

Broadband DSX

User Manual

Table of Contents

- Chapter 1: Description 1**
 - 1.1 Overview 1
 - 1.1.1 Capabilities 1
 - 1.1.2 Features 1
 - 1.1.3 Applications 2
 - 1.1.3 Part Numbers 2
 - 1.2 Main Assemblies 3
 - 1.3 Specifications 4
 - 1.3.1 Electrical 4
 - 1.3.2 Environmental 4
- Chapter 2: Installation 7**
 - 2.1 Installation Considerations 7
 - 2.1.1 Location and Space 7
 - 2.1.2 Tools and Equipment 7
 - 2.1.3 Technical Support 7
 - 2.2 Inspection 7
 - 2.3 Installation Procedure 8
- Chapter 3: Electrical 11**
 - 3.1 Power 11
 - 3.1.1 Tracer Lamp 11
 - 3.2 Signal Flow 12
- Chapter 4: Service 13**
 - 4.1 Owner Maintenance 13
 - 4.1.1 Replacing The Tracer Lamp LED 13
 - 4.1.2 Technical Support 13
 - 4.2 Troubleshooting: Cross-Connected Signals 13
 - 4.3 In-Warranty Service 13
 - 4.4 Out-Of-Warranty Service 13
 - 4.5 Repacking for Shipment 14

List of Figures

Figure 1 - Model 010-0000-0401 1
Figure 2 - System-Level Applications 2
Figure 3 - Chassis 3
Figure 4 - Backplane 3
Figure 5 - DSX Module 4
Figure 6 - Dimensions 5
Figure 7 - Connecting the Network Element Equipment 8
Figure 8 - Connecting the Messenger Wire 9
Figure 9 - Connecting the Ground Wire 9
Figure 10 - Terminating a Bus 11
Figure 11 - Tracer Lamp 11
Figure 12 - Signal Flow 12



Chapter 1: Description

1.1 Overview

Telect's Broadband Digital Signal Cross-Connect (DSX) is a high-density device for cross-connecting DS3, STS-1, and STS-3 signal types from broadband equipment, such as digital radio, fiber-optic multiplexers, and 3:3 or 3:1 DCS.

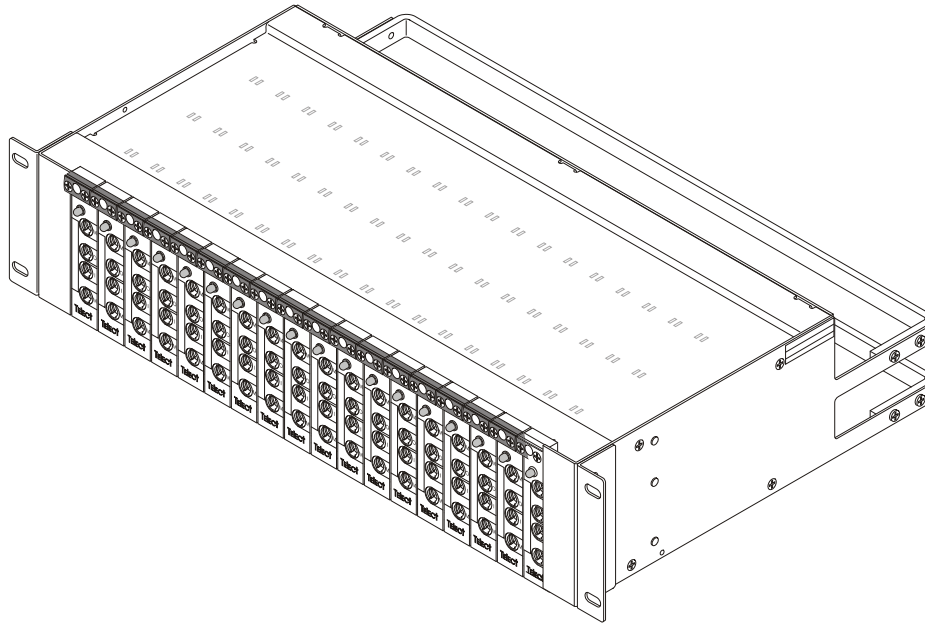

Figure 1 - Model 010-0000-0401

1.1.1 Capabilities

- Virtually “hitless” patching with terminate-before-break TwistLok™ (TLJ™) jacks
- Backplane can be preterminated and cross-connect assignments prewired
- Bidirectional monitoring

1.1.2 Features

- Plug-in DSX cards to turn up circuit
- Holds up to 48 modules (8" x23" chassis)
- Uses industry standard patch cords
- Mini-WECO jacks and BNC, TNC, or 1.6/5.6 connectors
- Cable tie-down bars

1.1.3 Applications

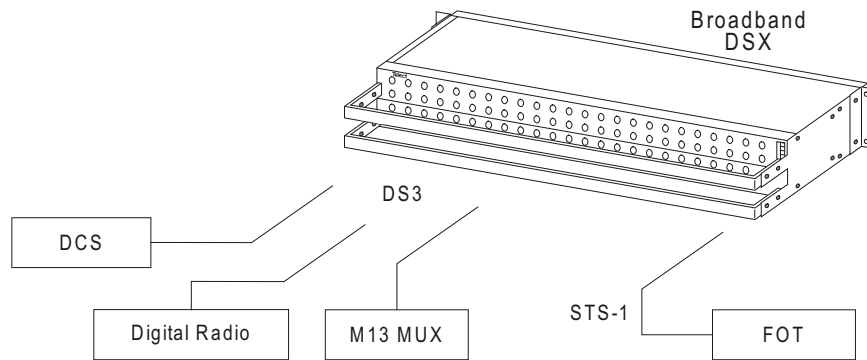

Figure 2 - System-Level Applications

1.1.3 Part Numbers

The information in this manual applies to the following part numbers:

Chassis #	Height	Width	Positions	Connectors	Tracer Lamp Terminations
010-0000-0401	4"	19"	18	BNC	PJ
010-0000-0402	4"	19"	18	BNC	PJ
010-0000-0471	2"	19"	8	BNC	PJ
010-0000-1401	4"	23"	24	BNC	PJ
010-0000-1402	4"	23"	24	BNC	na
010-0000-1403	4"	23"	24	BNC	WW
010-0000-1404	4"	23"	24	BNC	PJ
010-0000-1448	8"	23"	48	BNC	PJ
010-0000-1460	8"	23"	48	BNC	PJ
010-0000-1471	2"	23"	10	BNC	PJ

Module #	Jacks	# of Ports
010-8401-0401	Mini-WECO	4
010-8401-0406	Mini-WECO	3
010-8401-0410	Mini-WECO	6
010-8411-0401	Standard WECO	4
010-8411-0407	Standard WECO	3

1.2 Main Assemblies

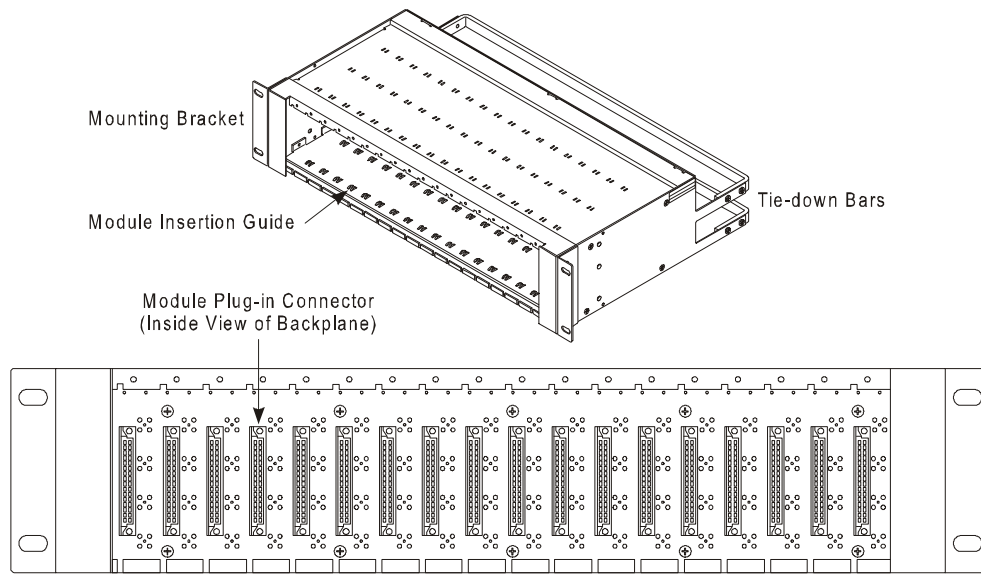

Figure 3 - Chassis

Part #010-0000-0401 Shown

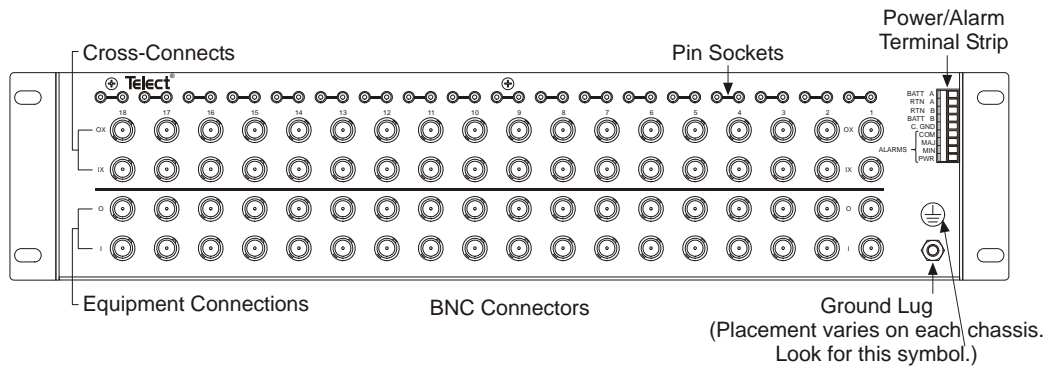

Figure 4 - Backplane

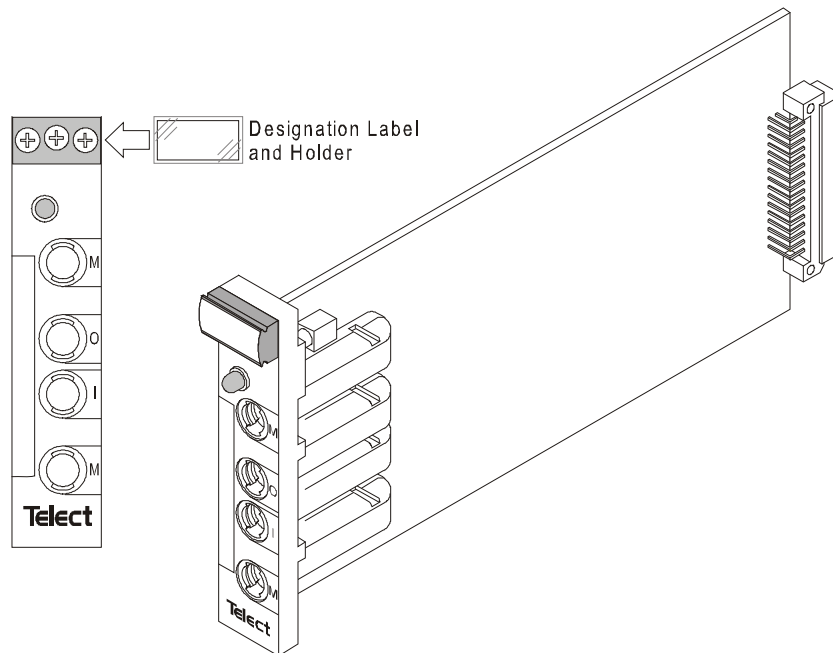

Figure 5 - DSX Module

1.3 Specifications

1.3.1 Electrical

Digital Signal: E3 (34.368 Mbps), T3 (44.736 Mbps), STS-1 (51.84 Mbps), or STS-3 (155 Mbps)

Insertion Loss: 0.6 dB \pm 0.55, 8 MHz to 240 MHz, at signal rate

Return Loss: \leq -15 dB, 8 MHz to 240 MHz, STS-3 signal rate,
 \leq -26 dB, T3/E3/STS-1 signal rates

Crosstalk: \leq -60 dB, 8 MHz to 240 MHz, at signal rate

Monitor Level: 20 dB \pm 1.5 dB below signal level

Contact Resistance: \leq 0.01 Ω

Characteristic Impedance: 75 Ω

Tracer Lamp LED: Draws 9 mA

1.3.2 Environmental

Temperature: -67 $^{\circ}$ to 185 $^{\circ}$ F (-55 $^{\circ}$ to 85 $^{\circ}$ C)

Thermal Shock: Per MIL-STD 202, method 107D

Humidity: To 95% noncondensing (operating and nonoperating)

Chassis #010-0000-0401 Shown

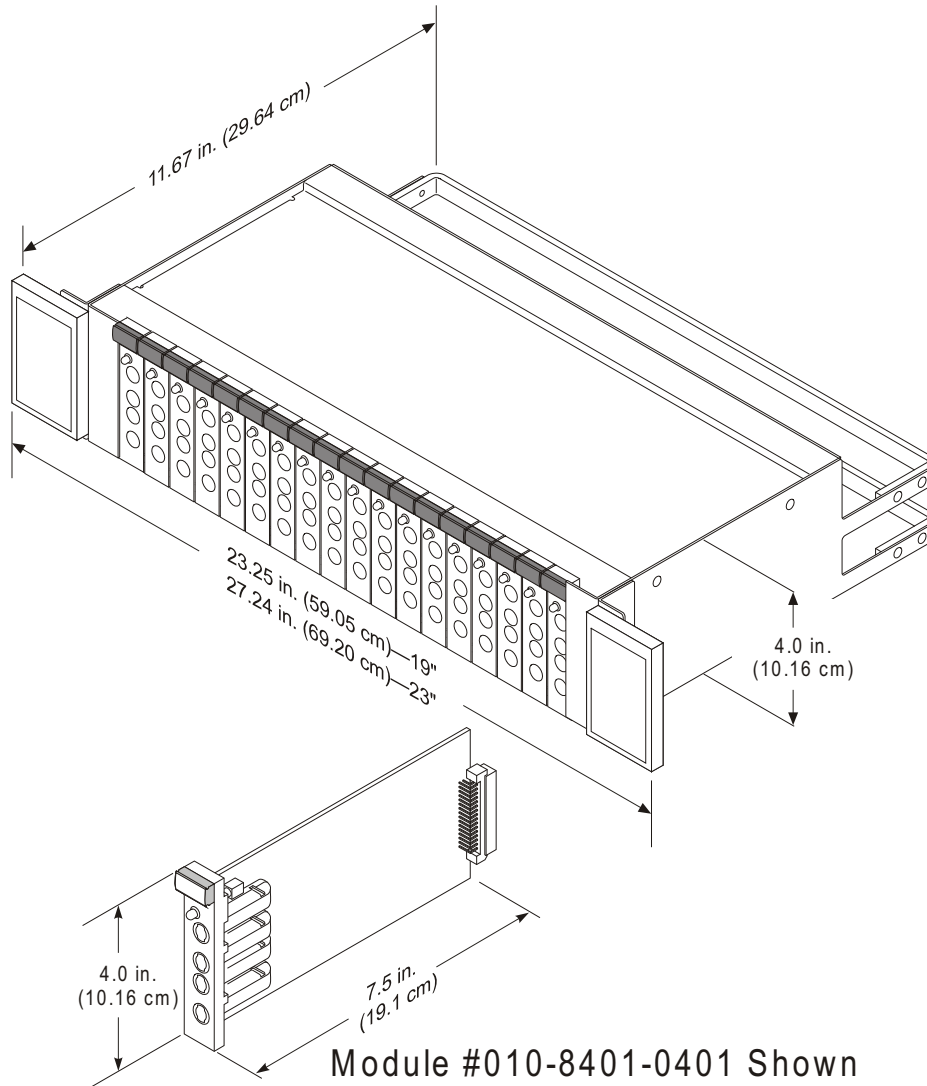

Module #010-8401-0401 Shown

Figure 6 - Dimensions

This page intentionally left blank.

Chapter 2: Installation

2.1 Installation Considerations

CAUTION

CAUTION! Only qualified personnel may install and maintain this product.

CAUTION

CAUTION! Do not supply power until all connections are made in accordance with requirements specified in local electrical codes. Protect this equipment with an approved fuse or breaker sufficiently rated to interrupt power at -48 Vdc at 2 amps, or as specified on the device. Only use components and crimping tools approved by agencies or certifying bodies recognized in your country or region such as Underwriter's Laboratories (UL), TUV, etc.

CAUTION

CAUTION! Install this equipment in locations accessible **ONLY** to qualified persons.

ALERT

ALERT! These instructions presume you have verified that the Telect equipment being installed is compatible with the rest of the system, including power, ground, circuit protection, signal characteristics, equipment from other vendors, and local codes or ordinances.

2.1.1 Location and Space

Depending on its size, the Broadband DSX mounts in 19" or 23" WEKO-spaced racks (1-inch-on-center mounting holes) and uses 2", 4", or 8" of vertical space.

2.1.2 Tools and Equipment

No special tools or equipment are required.

2.1.3 Technical Support

By e-mail: getinfo@telect.com

By phone: 888-821-4856 or 509-921-6161

2.2 Inspection

Please read these instructions carefully before beginning installation. If you need assistance, call Technical Support at 1-888-821-4856 (domestic calls), or 509-921-6161 (Option 2), or email us at getinfo@telect.com.

Inspect equipment after unpacking and compare it to the packing list.

Immediately report any shipping damage, defects, or missing parts to Telect at 1-800-551-4567. Keep all documentation that comes with your shipment.

Telect is not liable for shipping damage. If the product is damaged, notify the carrier and call Telect's Customer Service Department at 1-800-551-4567 (domestic only) or 1-509-926-6000 for further recourse.

NOTE: For service or warranty information, please visit the telect.com website, or email inquiries to getinfo@Telect.com and click on the "Support" tab, or phone us at 800-551-4567 (domestic only) or 509-926-6000.

2.3 Installation Procedure

1. Mount the Broadband DSX to the rack with the four mounting screws that come with the equipment.
2. Remove the top tie-down bar.
3. Starting with the lowest Broadband DSX in the rack and working up, connect the network element (NE) equipment to the lower pairs of connectors:

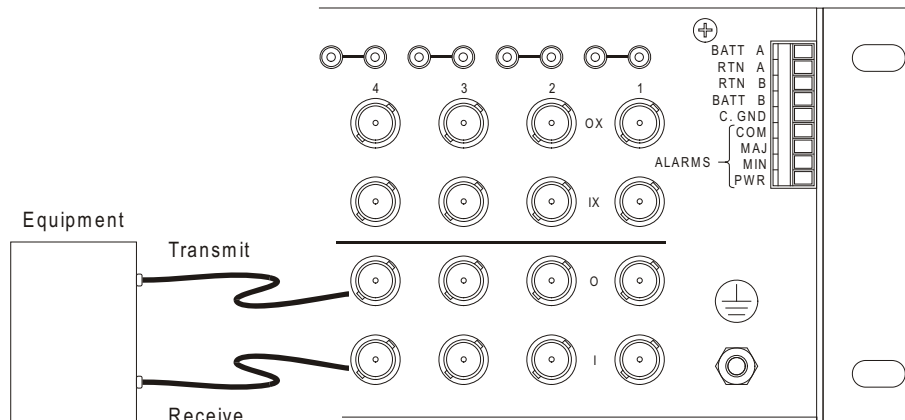

Figure 7 - Connecting the Network Element Equipment

4. Secure the cables to the lower tie-down bar.
5. Reattach the upper tie-down bar.
6. Install the cross-connects at the upper pairs of connectors, connecting "IX" of one piece of equipment to "OX" of another. The equipment must have both cross-connects: "IX" of Equipment A to "OX" of Equipment B, and "IX" of B to "OX" of A.

7. Connect the messenger wire to one of the pin sockets or wire wrap pins that pertain to the IX and OX of a cross-connect pair:

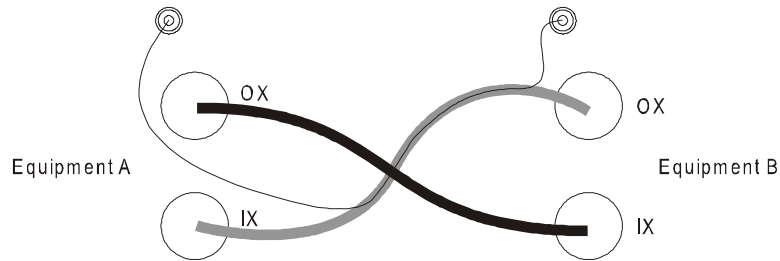

Figure 8 - Connecting the Messenger Wire

8. Secure the cross-connect cables from other Broadband DSXs to the upper tie-down bar.
9. Slide the plastic designation-label holders onto the DSX modules.
10. Connect a ground wire (14 AWG, minimum) with ring terminal to the ground lug:

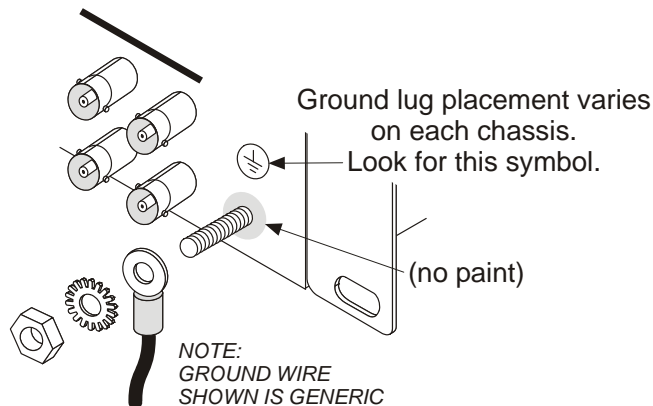

Figure 9 - Connecting the Ground Wire

11. Connect the office battery to the Power/Alarm Terminal Strip.
12. Insert the appropriate DSX modules to turn up the circuits you want.
13. Fill out the designation labels and insert them into the plastic holders on the DSX modules.

This page intentionally left blank.

Chapter 3: Electrical

3.1 Power

The Broadband DSX is passive equipment. It accepts -48V office battery power to light the tracer lamp (TL) LED on the front of the DSX modules. This power connects to the Power/Alarm Terminal Strip at the back of the equipment. The strip terminates a bus on the chassis backplane; all DSX module connectors on the backplane tap into the signal lines of this bus:

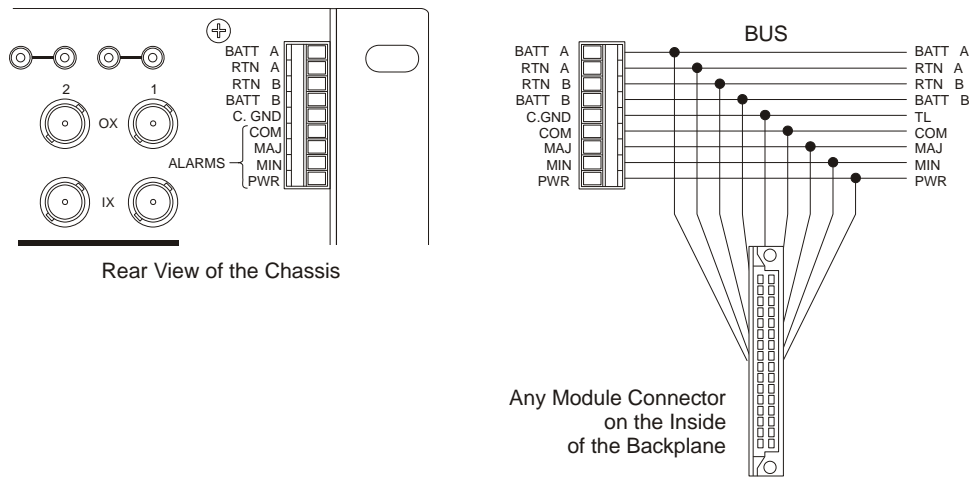

Figure 10 - Terminating a Bus

NOTE: When using an 8" chassis, you must connect both power supplies to power the chassis. This can be done by "daisy-chaining" them together.

3.1.1 Tracer Lamp

The TL lights only when a plug is inserted into one of the monitor jacks on the front of a DSX module, as shown in the following figure.

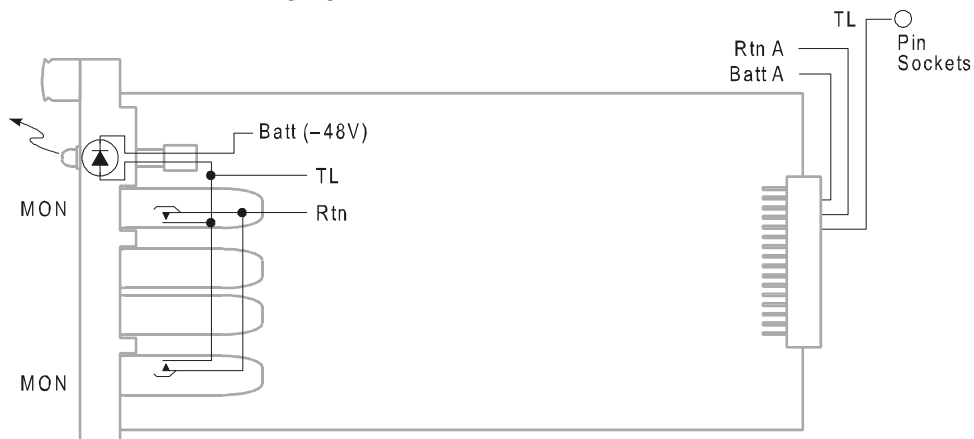

Figure 11 - Tracer Lamp

You can also connect TLs of cross-connected modules by attaching the messenger wire to one of the backplane pin sockets or wire wrap pins that corresponds to each of the connected modules. When one TL lights, the other flashes for about 30 seconds and then lights steady.

3.2 Signal Flow

The Broadband DSX generates no signals of its own. Connectors on the outside of the backplane are tied to PCB connectors on the inside. The “in” (I) and “out” (O) circuits connect to their corresponding cross-connects (IX, OX) only when a DSX module is inserted in a connector—the “in” and “out” jacks on the module close the circuits, as long as the jacks have no patch cords inserted.

Cables attached to the cross-connects on the backplane (IX, OX) take the “out” signals of one piece of equipment to the “in” circuit of another and vice versa. Inserting a patch cord in a module jack breaks the circuit established by the cross-connect cables, diverting the signal through the cord to another location.

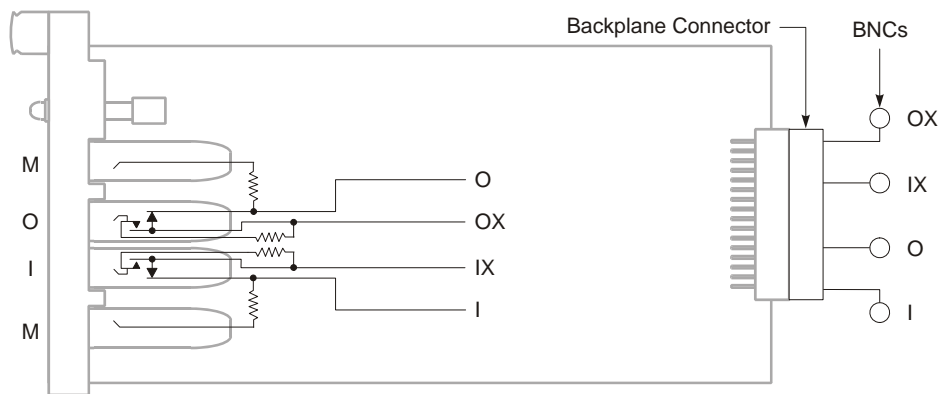

Figure 12 - Signal Flow

Chapter 4: Service



CAUTION! Only qualified technicians may install and maintain this product.

4.1 Owner Maintenance

Telect's Broadband DSX does not need preventive maintenance. The only service you can perform is to replace defective assemblies:

- DSX module
- Chassis
- Tracer lamp LED

4.1.1 Replacing The Tracer Lamp LED

Pull the LED assembly and plastic holder straight out.

If LED polarization is not correct, the replacement will not work. Orient the new LED in the plastic holder the same as the original. The shape of the LED holder slot in the DSX module is “keyed” for proper LED insertion.

4.1.2 Technical Support

By e-mail: getinfo@telect.com

By phone: 888-821-4856 or 509-921-6161

4.2 Troubleshooting: Cross-Connected Signals

Check for correct and firm cable connections at the termination and cross-connect points of the Broadband DSX.

4.3 In-Warranty Service

Contact Telect's quality call center at 877-471-7245 or e-mail us at quality@telect.com. Telect will ship a new replacement product, along with a return shipping label and authorization information. When you receive your replacement product, pack up the defective product and return it to Telect using the return label, box and any additional information provided.

4.4 Out-Of-Warranty Service

Follow the In-Warranty directions above. Telect charges a processing fee for out-of-warranty service, and you must submit a Purchase Order along with a Return Material Authorization (RMA) before returning equipment. The processing fee guarantees a repair estimate and is

credited against actual material and labor costs. Call Telect's quality call center at 877-471-7245 for more information.

4.5 Repacking for Shipment

1. Tag the equipment showing owner's name, address, and telephone number, together with a detailed description of the problem.
2. Use the original shipping container if possible. If you do not have it, package the equipment in a way to prevent shipping damage. Include the RMA inside the container and legibly print the RMA number on the outside of the package, near the shipping address.
3. Insure the package.